

# CC560 - Capping Machine

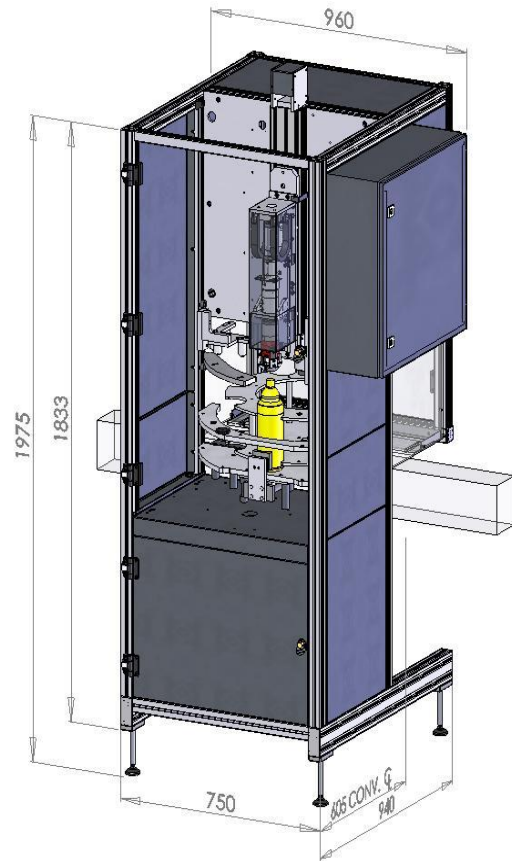

Cap Coder Ltd enjoys an excellent reputation in various sectors of the Packaging Industry, including pharmaceutical, cosmetic, adhesive, aromatherapy, diagnostic, household goods & food industry. Cap Coder works together with its customers to Design, Build and Develop Machines that convey, plug, cap, orientate and code containers to suit the application required.

The **CC560** machine is just one of the machines offered that can be supplied to suit the requirements of the customer, with options such as, single-head or twin-head automatic capping, press-on capping and cap-tightening manually applied caps, including trigger-spray types and pump-action spouted types.



Cap	Cap Shape	Any shape considered, Trigger spray nozzles if pre-placed
	Cap Type	Plain, Tamper-Evident, Trigger and Pump Spray
	Cap Size	Ø10mm - Ø120mm Semi Auto & single head fully automatic. Ø10mm - Ø65mm Twin Head fully automatic
	Cap Application	Torque & Speed controllable. Pick & Place Option. Press on
Container	Container Shape/Type	Any shape and material type considered
	Container Volume	50ml - 5ltr
	Container Height	Maximum 320mm using Standard machine frame
Control	PLC	Allen Bradley as standard. Client preference as required
Electrical	Servo Drives	Baldor, Dunkermoteren
	Electrical Controls	Télémechanique, Pilz, Keyence
	Electrical Supply	240v Single phase – 13 Amp via MCB “D” rated
	Electrical Consumption	Max 1kW
Pneumatic	Pneumatic Systems	Festo, Rexroth
	Air Pressure	5 bar
	Air Consumption	Notionally 30Ltr/min subject to operation
Construction	Dimensions	965mm (inc control box) (w) x 940mm (d) x 1975mm (h)
	Weight	210Kg
	Build Standard	EC Declaration of Conformity. Zone 2 Compatible if operationally required. IP 65 rated
	Machine Construction	Standard machine, anodised aluminium extrusion framework, stainless steel base cover and panels, polycarbonate guard doors. Options for stainless steel frames and glass doors
Options	Additional Options	Bowl Feeders, Bulk Hoppers, Conveyors, Rotary Tables, Press Heads, Adjustable Starwheel, Filling Station, Cap Check
	Change Parts	Starwheels, Torque Head gripping jaws, clamps & fences, press pads, cap nests or pegs
Production Rate	Cap Tightening, Single Head	Up to 50 per minute
	Automatic Capping, Single Head	Up to 30 per minute
	Automatic Capping Twin Swing Head	Up to 40 per minute